

8	7	6	5	4	3	2	1
No. COMPONENTS IN ASSLY	OP1	OP2	OP3	OP4	OP5	OP6	
<b>1</b>							

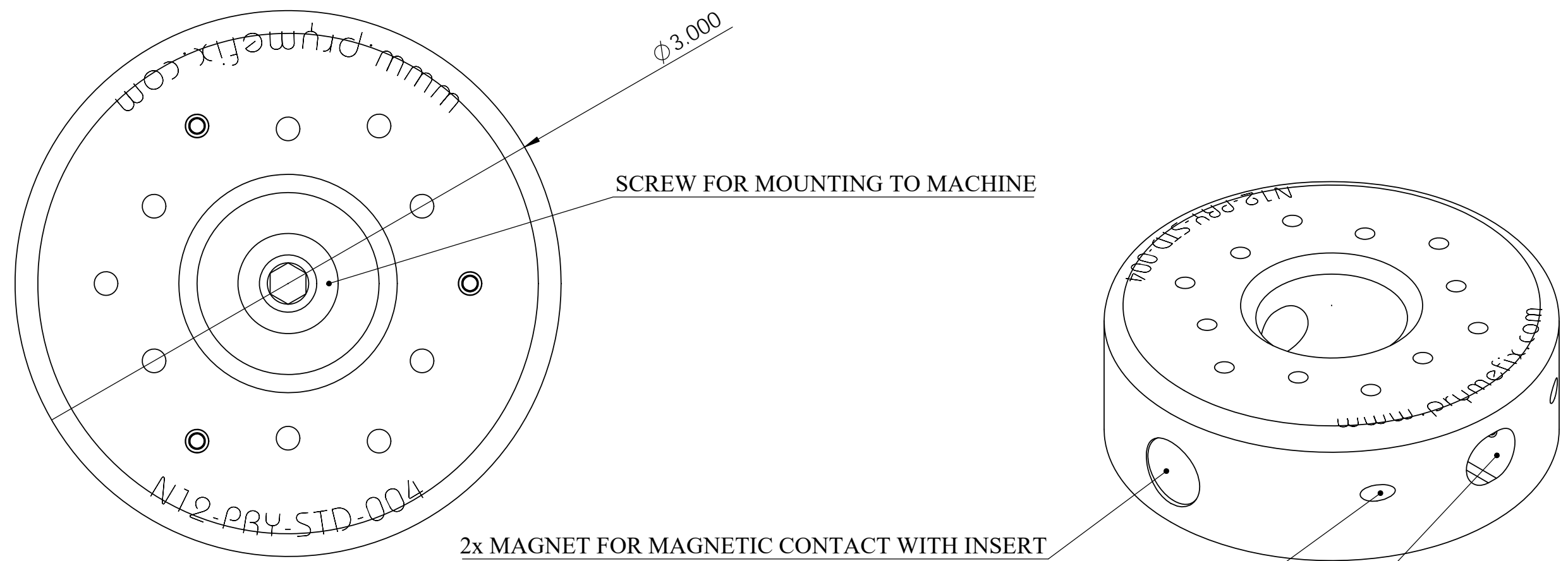

SCREW FOR MOUNTING TO MACHINE

2x MAGNET FOR MAGNETIC CONTACT WITH INSERT

4x SET SCREW FOR LOCKING GUIDE RAIL

SLOT FOR GUIDE RAIL

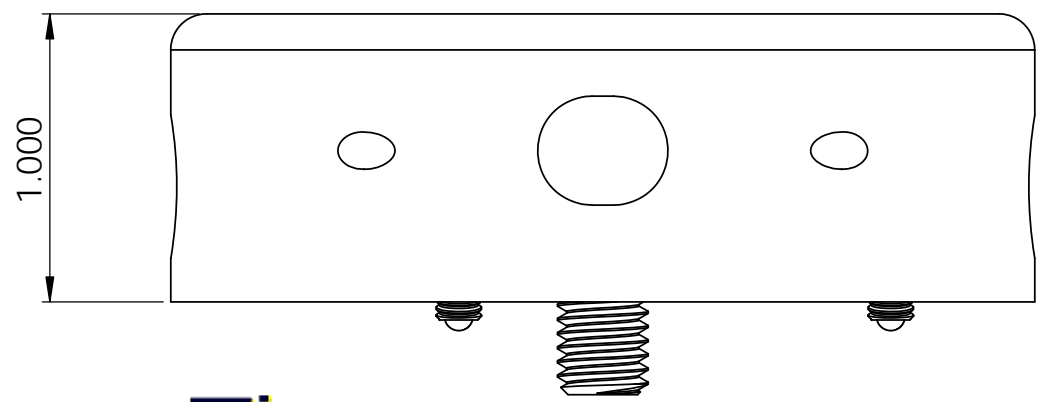

**PrymeFix**  
fixturing solutions

155 PRAIRIE LAKE RD, SUITE A  
EAST DUNDEE, IL 60118  
847.428.7122

FILE NAME	N12-PRY-STD-004
DIRECTORY	P:\Manufacturing\PrymeFix Product Line\C11 & N11 Corner Inserts & Nests\N12-PRY-STD-001\

**PROPRIETARY AND CONFIDENTIAL**

THE INFORMATION CONTAINED IN THIS DRAWING IS THE SOLE PROPERTY OF PRYMETECH. ANY REPRODUCTION IN PART OR AS A WHOLE WITHOUT THE WRITTEN PERMISSION OF PRYMETECH IS PROHIBITED.

1		UNLESS OTHERWISE SPECIFIED	DRAWN BY:	<b>AK</b>	DATE	8/6/2014	
2			FRACTIONAL ± .003 ANGULAR: ± 1.0 TWO PLACE DECIMAL ± .010 THREE PLACE DECIMAL ± .003 FOUR PLACE DECIMAL ± .0005 (REAM)	TITLE:			N12-PRY-STD-004
3				SIZE			<b>B</b>
4				DWG. NO.			N12-PRY-STD-XXX Prints
5			HEAT TREAT	N/A	No Pcs to Complete Order:		
6			MATERIAL	6061 Alloy			
7			FINISH	HARDCOAT ANODIZED			
REVISION HISTORY		INCH UNITS	SCALE: 2:1	WEIGHT: 0.57	SHEET 12 OF 12		