

ZEISS CARMET®

Specifications

Last updated: 2020-10



Seeing beyond

System description

Type according to ISO 10360-1:2000	Moving ram horizontal-arm CMM		
Models	Single or duplex		
Operating mode	Motorized / CNC		
Sensor mounts	ZEISS RDS-C6 CAA		
Software	ZEISS CALIGO, ZEISS HOLOS, I++		
Travel speed	Motorized	Axes	0 to 150 mm/s
	CNC	X axis	max. 200 mm/s
		Y axis	
		Z axis	
Acceleration	Vector		346 mm/s
	Axes		max. 200 mm/s ²
	Vector		max. 346 mm/s ²

Accuracy and measuring performance ¹⁾

The functionality of the device and its specifications are only guaranteed when using original accessories by ZEISS. The specified parameters are observed in the application of the internal test instructions for acceptance testing and in the use of the released standards in accordance with the ISO 10360 series.

				16/25
Length measurement error MPE complies with ISO 10360-2:2001	E for single arm	in µm	at 16 °C - 24 °C	35+L/50 ≤80
Length measurement error MPE complies with ISO 10360-2:2001	EM for dual arm	in µm	at 16 °C - 24 °C	50+L/40 ≤120
Probing error MPE complies with ISO 10360-2:2001	P for single arm	in µm	at 16 °C - 24 °C	30

Technical features

Length measuring system	Steel scales, 1 µm resolution		
Controller	Type	ZEISS C99L	
	Protection type	IP22	
Accessories (optional)	Various control panels, passive multi-sensor rack for storage of stylus systems		



Environmental requirements ²⁾

Ambient temperature			16 °C - 24 °C
	Temperature fluctuations	Per hour	1.5 K/h
		per day	3.0 K/d
	Temperature gradient	Spatial	1.0 K/m
Relative humidity	40 % - 80 % (without condensation)		

Requirements for operational readiness

Relative humidity	90 % maximum without condensation
Ambient temperature	10 °C - 35 °C
Electrical power rating	1/N/PE 100-240 VAC~, (+/-10%), 50/60 Hz (+/-3.5%) Max. power consumption when fully upgraded 600 VA
Compressed air supply	Supply pressure 6-10 bar, pre-cleaned, use approx. 0,8 Nl/min operating pressure Air quality complies with ISO 8573 part 1: class 4

Approvals

Regulations	ZEISS CARMET complies with EC machine directive 2006/42/EC and EMC directive 2014/30/EU and the RoHS directive 2011/65/EU.
	  
Disposal	ZEISS products and packaging returned to us are disposed of in accordance with applicable legal provisions.

Certification/accreditation

Quality management system	ISO 9001:2015; VDA 6, Parts 4, 3. Version 2017
Environmental management system	ISO 14001:2015
Occupational health & safety management systems	BS OHSAS 18001:2007
Accredited	ISO/IEC 17025:2005

1) L = measuring length in mm.

2) To ensure specified length measuring uncertainty

Sensor mounts

ZEISS RDS-C6 CAA

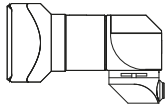

Standard for ZEISS CARMET

Dynamic ZEISS RDS-C6 CAA articulating unit for contact and optical sensors.
The lateral tilting axis provides more advantages over articulating units with front-to-back and lateral tilting axis: tilting range of $\pm 180^\circ$, large measuring range.
With CAA correction for automatic calibration of all available angular settings.
With collision protected probe plate.

Step width	2.5°
Angular velocity	up to 90°/s
Reproducibility of the position	$\pm 1''$
Maximum torque	50 Ncm
Max. extension	350 mm with ZEISS RST-P
	350 mm (PECF) with Renishaw TP6
	350 mm (PECF) with Renishaw TP20

Sensors

Renishaw TP6



Standard for ZEISS CARMET; 3D touch-trigger probe, manufactured by Renishaw

Length	41 mm
Diameter	25 mm
Measuring force	0.11 - 0.30 N
Stylus length	max. 50 mm
Stylus weight	max. 5 g

Renishaw TP20



Option for ZEISS CARMET; 3D touch-trigger probe, manufactured by Renishaw

Length	38 mm
Diameter	13.2 mm
Measuring force (with stylus length of 10 mm)	0.08 N; 0.25 N; 0.4 N
Stylus length	max. 50 mm
Stylus weight	max. 5 g

ZEISS RST-P



Option for ZEISS CARMET; Directional-independent touch-trigger sensor

Length	65 mm
Diameter	24 mm
Measuring force at data acquisition	<0.01 N
Stylus length	max. 90 mm
Stylus weight	max. 10 g

ZEISS FalconEye



ZEISS CARMET option; laser line triangulation sensor with manual indexable 6th axis.
3 highly reproducible angular positions, 0°/45°/90°

Measuring range	100 mm
Line width	68 mm
Middle working distance	90 mm
Maximum error during sphere center test	90 μ m

The following features can be measured with ZEISS FalconEye directly as a feature or as a link: Elongated hole, point, square hole, cylinder/threaded rods, sphere, edge, gap and alignment, double sheet metal, point cloud

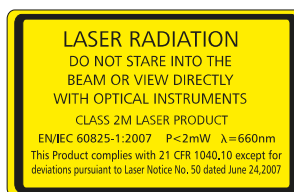

ZEISS CARMET sizes	Dimensions in mm										Weight in kg		
	Measuring range			Overall measuring machine dimensions							Assembly space	Measuring machine	X axis measuring beams
	X axis	Y axis	Z axis	Length		Width		Height					
	G104	G105	G106	B5	l1	B6	b1	B7	h1	c1			
Single arm													
40/16/25	4000	1600	2500	4995	995	2730	3960	3315	250	≥200	350	2000	
50/16/25	5000	1600	2500	5995	995	2730	3960	3315	250	≥200	350	2400	
60/16/25	6000	1600	2500	6995	995	2730	3960	3315	250	≥200	350	2800	
70/16/25	7000	1600	2500	7995	995	2730	3960	3315	250	≥200	350	3200	
Dual arm													
40/30/25	4000	3000	2500	4995	995	4930	7720	3315	250	≥200	350	2x2000	
50/30/25	5000	3000	2500	5995	995	4930	7720	3315	250	≥200	350	2x2400	
60/30/25	6000	3000	2500	6995	995	4930	7720	3315	250	≥200	350	2x2800	
70/30/25	7000	3000	2500	7995	995	4930	7720	3315	250	≥200	350	2x3200	

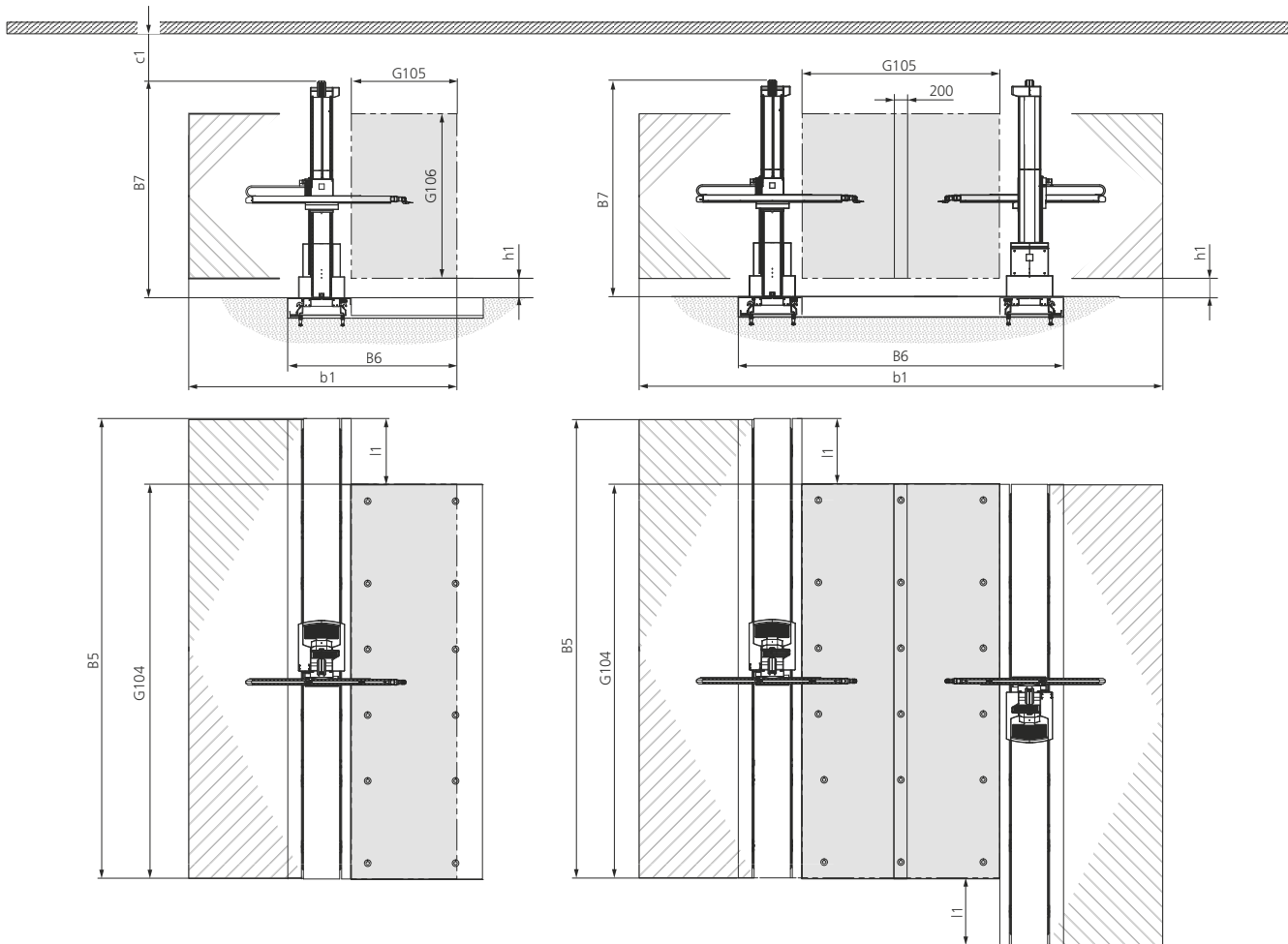

Note: the given dimensions and weights are approximate values. Subject to change. Actual appearance of specific sizes may vary from illustration. Dimensioning based on DIN 4000-167:2009.

EN_60_022_0342XV Printed in Germany. CZ-XI/2020
 Subject to change in design and scope of delivery and as a result of ongoing technical development.
 Printed on chlorine-free bleached paper. © Carl Zeiss Industrielle Messtechnik GmbH

Carl Zeiss Industrielle Messtechnik GmbH
 73446 Oberkochen / Germany
 Sales: +49 7364 20-6336
 Service: +49 7364 20-6337
 Fax: +49 7364 20-3870
 Email: info.metrology.de@zeiss.com
 Internet: www.zeiss.de/imt

Carl Zeiss Industrial Metrology, LLC
 6250 Sycamore Lane North
 Maple Grove, MN 55369/USA
 Phone: +1 763 744-2400
 Fax: +1 763 533-0219
 Email: info.metrology.us@zeiss.com
 Internet: www.zeiss.com/metrology